

Dichtungsbearbeitung: Seal machining:

Für Schlauchdichtung | for soft nose seal 74.025 / 74.026
In Kombination mit Wasserabweiser | In combination with water disperser 74.017

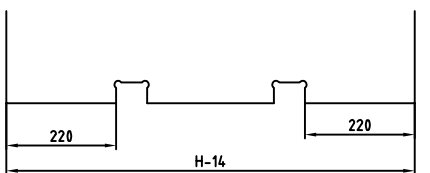

Oben
Top

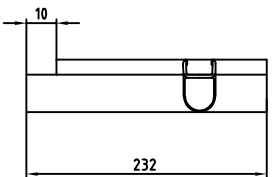

Unten
Bottom

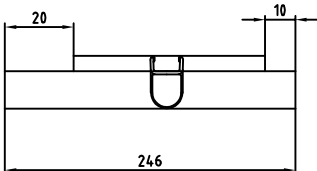

Mitte
Middle

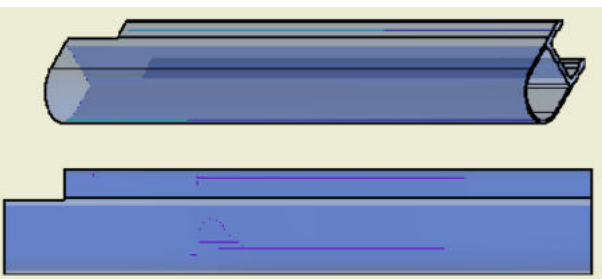
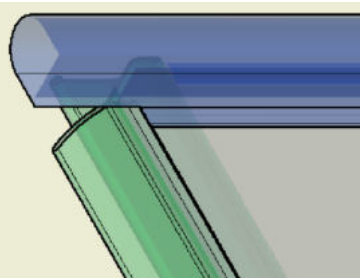
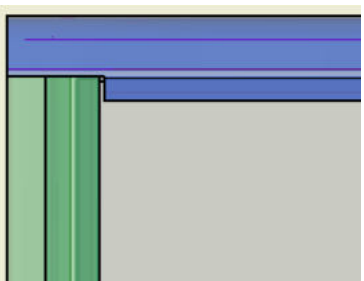
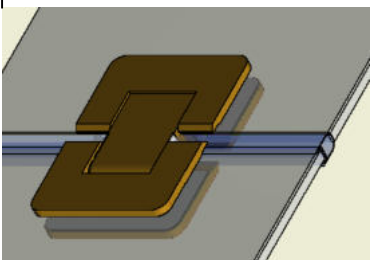
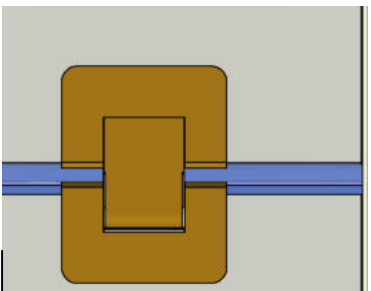
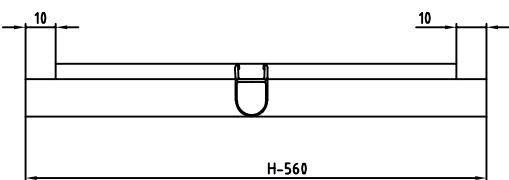

Detail Oben | Top

**Montageanleitung:
Pendeltürband BF 134
Band Glas/Glas 180°,
mit Federmechanismus
Art.-Nr.: 70.263**



Mounting instruction:

**Double-action hinge BF 134
Hinge Glass/glass 180°,
with spring mechanism
Art.-No.: 70.263**



Wichtige Informationen:

Glassstärke
8 mm
Tragfähigkeit (2 Bänder)
40 kg

Important information:

Glass thickness
8 mm
Load capacity (2 hinges)
40 kg

Vor der Montage Glasflächen
mit handelsüblichem Glasreiniger
im Bereich der Klemmflächen reinigen.
Keine Verdünnung verwenden.

All glass clamping areas are to
be cleaned with standard glass
cleaning products prior to installation.
Do not use thinners.

**Lieferumfang:
Scope of delivery:**

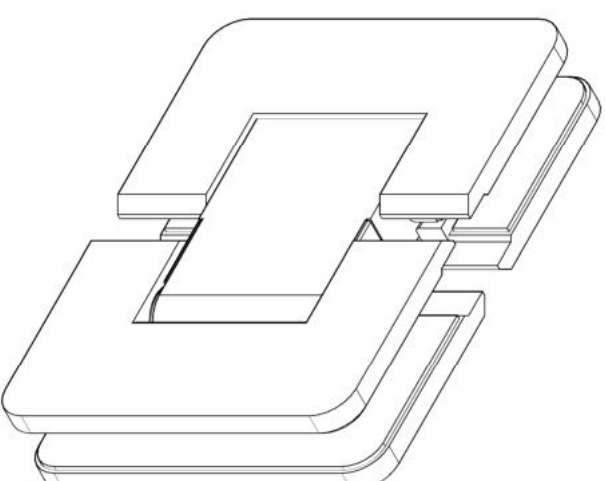

1. Vorbereitung des Pendeltürbandes:
Preparing the double action hinge:

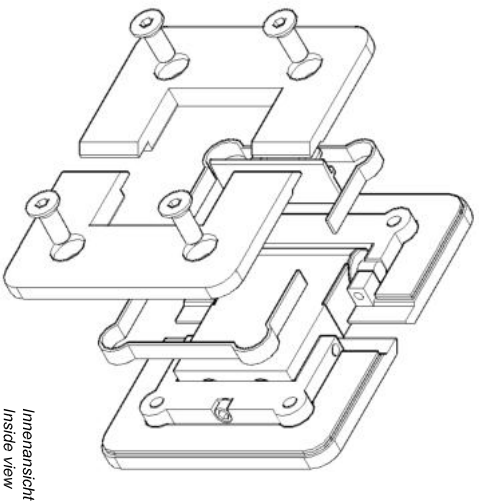

Innenansicht
 Inside view

2. Montage am Fixteil:
Assemble to the fixed panel:

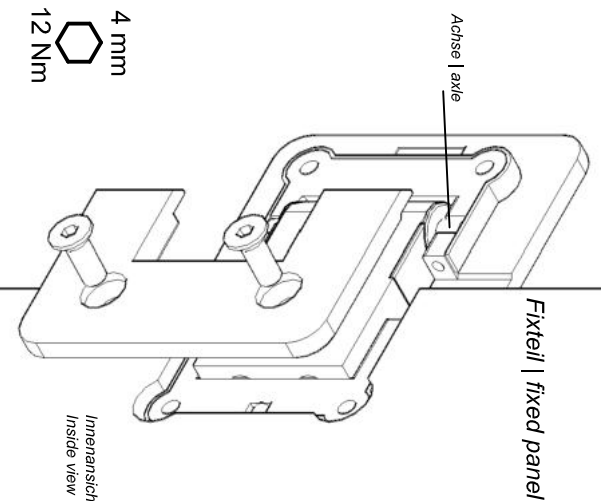

Fixteil | fixed panel

4 mm
 12 Nm

Innenansicht
 Inside view

Glassstärke: 8 mm / mit Dichtung
 Glass thickness: 8 mm / with seals

Glasbearbeitungen:
Glass preparations:

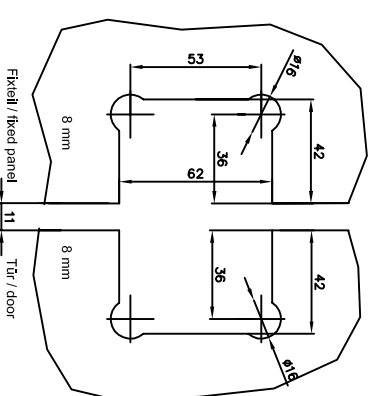
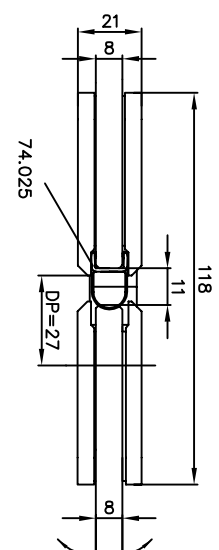

3. Montage an der Tür:
Assemble on door:

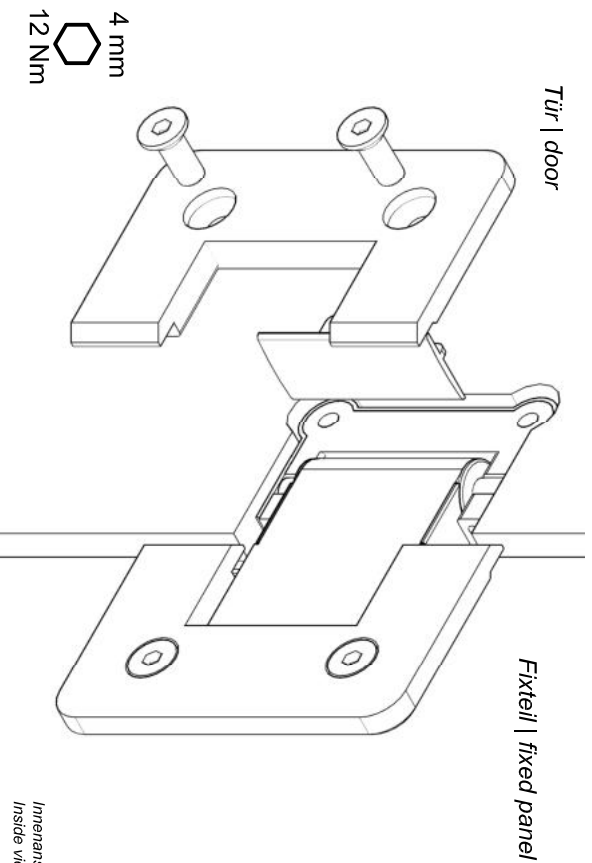

Tür | door

Fixteil | fixed panel

4 mm
 12 Nm

Innenansicht
 Inside view

Glassstärke: 10 mm / mit Dichtung
 Glass thickness: 10 mm / with seals

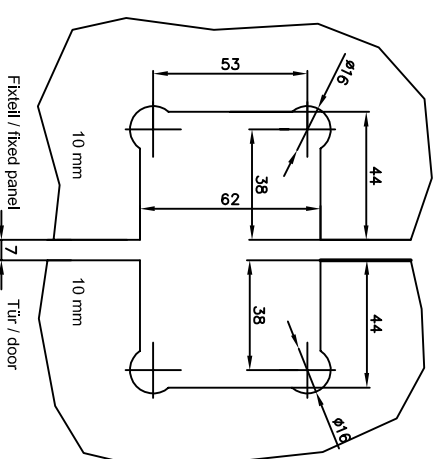
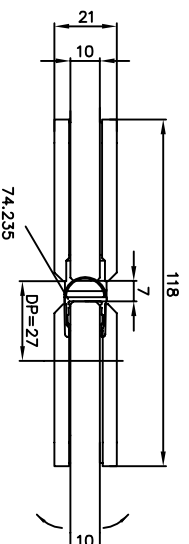

Fixteil / fixed panel

Tür / door